

Installation Manual

Nonlinear AV Workstation
Main Kit

WJ-MX1000AK

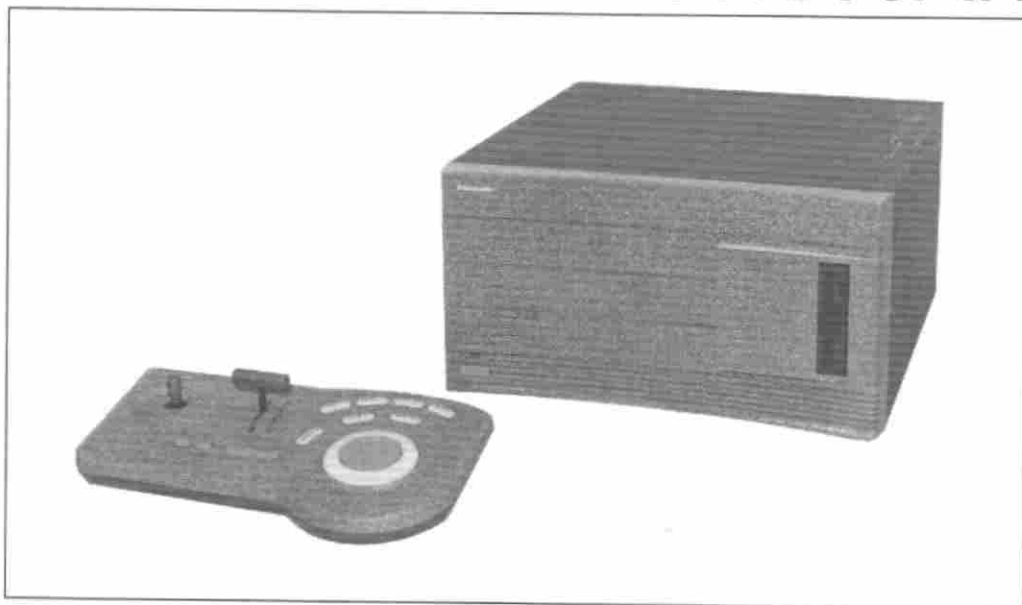

Panasonic[®]

Before attempting to connect or operate this product, please read these instructions completely.

PREFACE

The WJ-MX1000A Panasonic Nonlinear AV Workstation Main Kit is a combination of powerful hardware, flexible software and a custom human interface; developed for professional post-production. With the WJ-MX1000A AV Workstation, nonlinear editing is a creative process that finishes your videos to high standards while maintaining production budgets.

OPERATING CONDITIONS

The WJ-AS1000B (Ver.3.0 or later) application software is prerequisite.

FEATURES

Batch Digitizer

- VCR control for batch digitizing source bins for scene sorting
- Clip database includes in, out, reel, scene number, take number, comment, name
- Clip searching and sorting by keyword/Read reel number from user bits option

Sequence Editor

- "Drag & Drop" Scene placement - Insert, Replace, Cover modes
- Audio follow video on/off edit mode - 3 Layers of video tracks - Video, Key and Title
- Separate "effects" track for dissolves, wipes, Compression etc.
- Over 250 different effects (Inc. 3D DVE)
- Output of CMX compatible EDL

Audio Processing

- 4 layers of stereo audio tracks
- Equalizer and Reverb Effect

Character Generator

- Including 41 true type fonts
- Automatic crawl or roll
- Automatic Timing of title transitions

Paint Editor

- Retouch software Cut and Paste, Brush, Stencil, Airbrush, Draw
- Tiff format support

Dos 6.2 and Windows 3.1 are the registered trademarks of Microsoft Corporation.

PRECAUTIONS

- Do not expose the main unit or the jog pad to rain or moisture, and do not try to operate the equipment in wet areas. Do not operate the main unit or the jog pad if either becomes wet.
- Do not attempt to disassemble the main unit or jog pad. In order to prevent electric shock, do not remove screws or covers.
There are no user-serviceable parts inside.
- Do take immediate action if ever the main unit or jog pad should become wet. Turn the power off and have the unit checked by an authorized service facility.
- Do not interrupt the Vent Hole on the front panel. The main unit may over-heat and it may cause damage or even a fire.
- Be sure to remove the plug by grasping the plug and not the cord itself.
- Do not initialize the built-in hard disk.
- Use the main unit and the jog pad in an environment where the temperature is within 32°F - 95°F (0°C - + 35°C), and the relative humidity is within 10 - 90%.
- Handle the unit with care.
Do not abuse the main unit or jog pad. Avoid striking, shaking, etc. It could be damaged by improper handling or storage.
- Do not use strong or abrasive detergents when cleaning the unit and jog pad.
Do use a dry cloth to clean the unit when dirty. In case the dirt is hard to remove, use a mild detergent and wipe gently.
- The input power source is 120V AC 60 Hz.

MAJOR OPERATING CONTROLS AND THEIR FUNCTION

FRONT PANEL

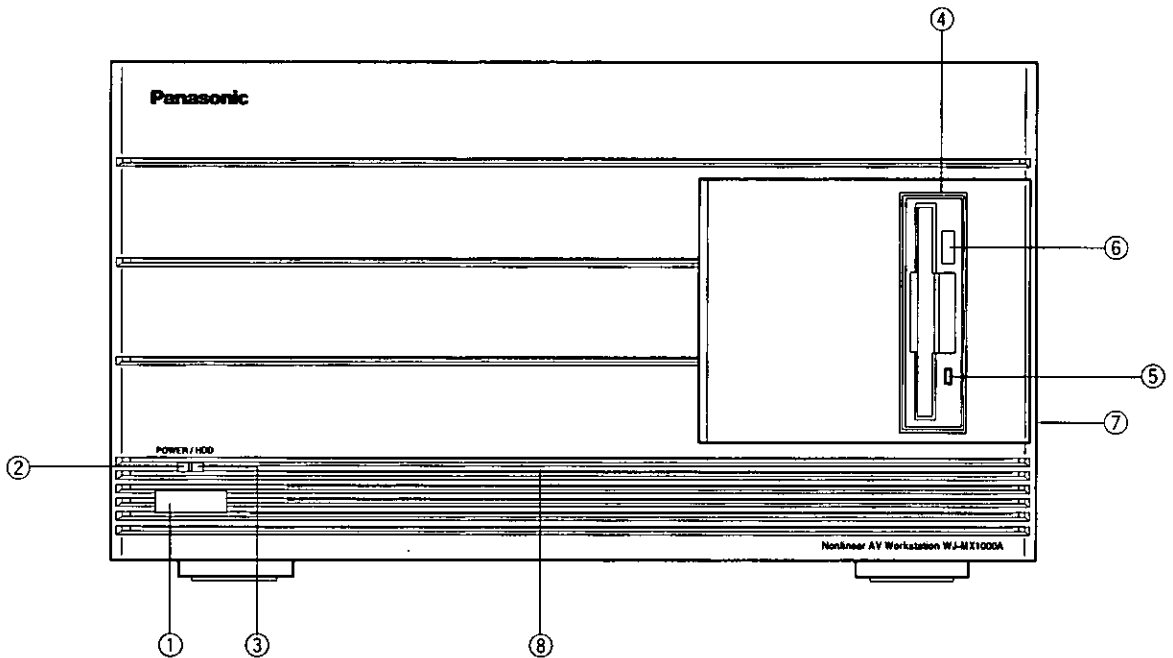

1. Power On/Off Switch

Turns the power of this unit on and off.

Notes :

1. Be sure to turn on the power of this unit after turning on the Hard Disk Box.
2. Do not turn off the power of this unit while the Nonlinear AV Workstation System software is running.

2. Power Indicator (RED)

Lights by turning on the power.

3. HDD Indicator (GREEN)

Lights up while the HDD operates.

4. 3.5" Floppy Disk Drive

5. Floppy Disk Indicator

Lights during an access of the floppy disk.

6. Eject Button

Ejects the Floppy Disk.

7. Front Panel Remove Button

Removes the Front Panel.

8. Front Panel

Caution: Do not interrupt the Vent Hole on this panel.

REAR PANEL

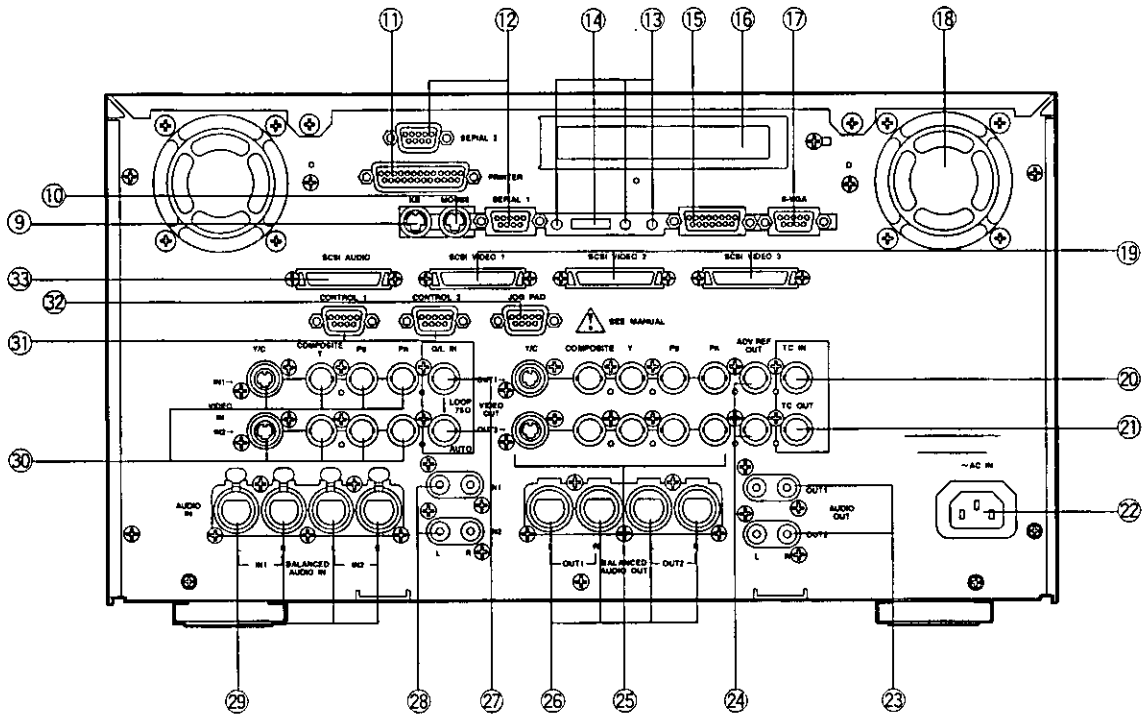

9. KEYBOARD Connector (KB)

Connects with the keyboard (local purchase).
If the cable is too short to connect, use the Key Board Extension Cable (accessory).

10. MOUSE Connector (MOUSE)

Connects with the Mouse (local purchase).
If the cable is too short to connect, use the Mouse Extension Cable (accessory).

11. PRINTER Connector (PRINTER)

Connects with the printer.

12. SERIAL 1 / 2 Connectors (SERIAL 1/SERIAL 2)

Connects with equipment having RS-232C Interface Connectors.

13.

Not used.

14.

Not used.

15.

Not used.

16. ISA Slot

Refer to qualified service personnel.

17. S-VGA Connector (S-VGA)

Connects with the computer display.
The applicable display parameters are shown below.
Resolution: 1024 x 768
Horizontal Scanning Frequency: 35 kHz
Vertical Scanning Frequency: 86 Hz

18. Fan

Supplies steady forced air through intake and filter.

Note: After extensive use the fans need to be replaced periodically.

Operating Time	Operating Life
8-hour everyday use	6-year
12-hour everyday use	4-year
24-hour everyday use	2-year

19. SCSI VIDEO Connectors (SCSI VIDEO 1-3)

Connects with the SCSI Video Connector of the Hard Disk Box WJ-EB1000 via the optional SCSI Cable WJ-CA10SR3.

20. TC(Time Code) IN Connector (TC IN)

Connects with a VCR having LTC time code signal output connector to improve editing accuracy.

21. TC(Time Code) OUT Connector (TC OUT)

Connects with a VCR having LTC time code signal input connector.

The signal supplied from this connector is not looped through.

22. AC Inlet

Connect the AC Power Cord (provided)

**23. AUDIO OUT 1 / 2Jacks
(AUDIO OUT OUT1, OUT2 L/R)**

Supplies the audio signals.

24. ADV-REF OUT Connector (ADV-REF OUT)

Supplies the Advance Reference Signal to a VCR having a time base corrector inside (or AUX video source).

**25. Video Output Connectors
(VIDEO OUT1/OUT2 Y/C, COMPOSITE, Y, Pb, Pr)**

Supplies the video signal to the monitor or VCR.

**26. AUDIO OUT 1/2 Connectors
(BALANCED AUDIO OUT, OUT1/OUT2)**

Supplies the audio signals.

27. G/L IN / AUTO Connectors (G / L, IN/AUTO)

The gen-lock signal is supplied to these connectors (Be sure to terminate the video signal output from these connectors).

By connecting with the G/L AUTO Connector, the video signal is automatically unterminated.

Caution:

If a gen-lock signal is supplied to the G/L connector during playback or recording, it may cause the video to roll or cause other system malfunction.

Stop the playback or recording, then make the connection to the G/L connector again.

28. AUDIO IN 1/2 Jacks (IN1, IN2 L/R) (Unbalanced)

Accepts the audio signal.

The audio signal supplied to these jacks can be saved in the Hard Disk Box.

When the audio signal is supplied to the L side only, a monaural audio signal is made.

**29. AUDIO IN 1/2 Connectors
(BALANCED AUDIO IN IN1 L/R, IN2 L/R)**

Accepts the audio signal.

The audio signal supplied to these connectors can be saved in the Hard Disk Box.

**30. Video 1/2 Input Connectors
(VIDEO IN1/IN2 Y/C, COMPOSITE, Y, Pb, Pr)**

Accepts the video signals to be saved in the Hard Disk Box.

Select the connector, either Composite, Y/C or Component, according to the type of video signal.

The selection of either Video 1/Video 2 is available on the PC monitor screen.

**31. CONTROL 1/2 Connectors
(CONTROL 1 /CONTROL 2) (9-pin)**

Supplies the control signal (for the recording or play back mode) to equipment having an RS-422 Interface Connector.

Be sure to supply the video signal of the VCR connected with CONTROL 1 to VIDEO IN 1, and likewise with the VCR connected to CONTROL 2.

32. JOGPAD Connector (JOGPAD)

Connects with the Jogpad (provided).

33. SCSI AUDIO Connector (SCSI AUDIO)

Supplies the audio signal to the SCSI Audio Connector of the optional Hard Disk Box via the optional SCSI Cable WJ-CA10SR3.

■ JOG PAD

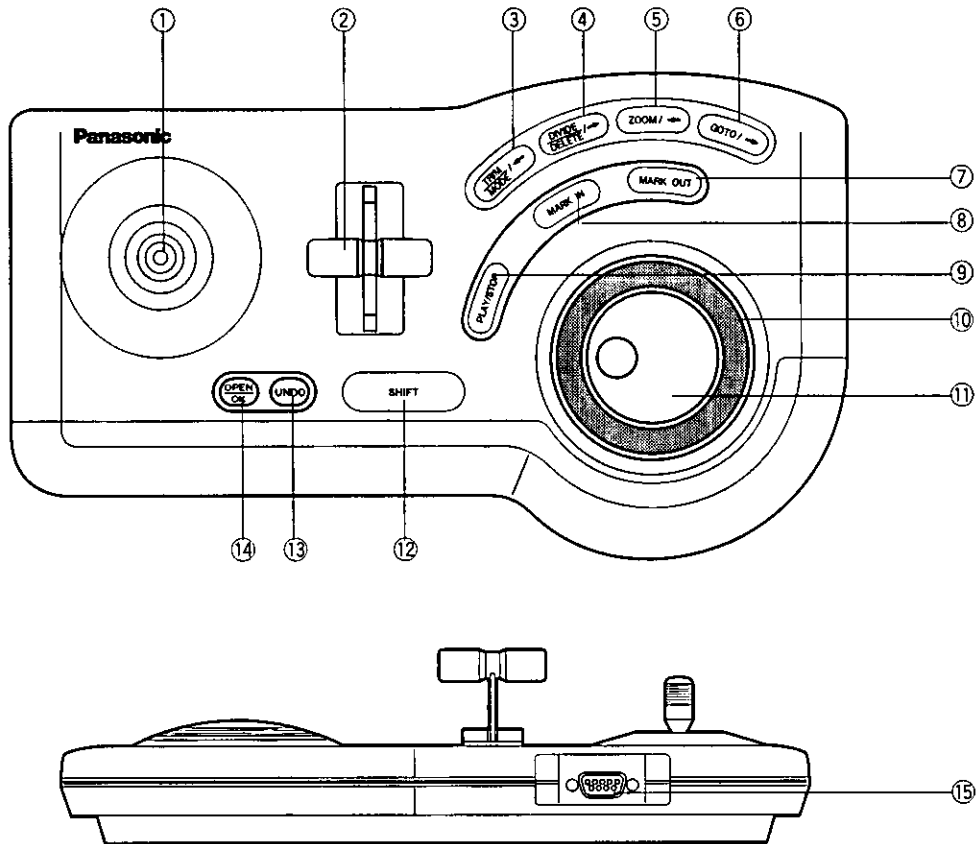

1. Positioner

Moves the selection cursor (when selection is confirmed).

2. Wipe Lever

Controls Wipe, Key Size, and Audio Level.

3. TRIM / MODE /

Switches edit modes (Insert - Replace - Cover)
(SHIFT + TRIM/MODE) Turns Trim mode On/Off
(during transition)

4. DIVIDE / DELETE

Deletes a clip.
(SHIFT + DIVIDE / DELETE) Divides a clip

5. ZOOM /

Zooms in the time line
(SHIFT + ZOOM) Zooms out the time line.

6. GOTO /

Jumps to the starting or editing mark
(SHIFT + GOTO) Jumps to the beginning or end
of a sequence.

7. MARK OUT

Sets or cancels the ending mark.
(SHIFT + MARK OUT) Selects the grip of the OUT
point.

8. MARK IN

Sets or cancels the starting mark.

(SHIFT + MARK IN) Selects the grip of the IN point.

9. PLAY / STOP

Plays back or stops.

(SHIFT + PLAY /STOP) Plays back between the starting and ending marks.

10. Shuttle Ring

Plays back video and audio forward (clockwise) or in reverse (counterclockwise) with variable speed.

11. Jog Dial

Plays back video and audio forward (clockwise) or in reverse (counterclockwise) frame by frame.

12. SHIFT

Switches button functions.

13. UNDO

Cancels the immediately previous operation.

14. OPEN / OK

Opens the selected panel or selects a panel and closes the previous panel.

15. Jog Pad Connector

Connects with the Main Unit by using the Jog Pad Cable (accessory).

CONNECTION

These connections should be made by qualified service personnel or system installers.

■ Cable Information





Necessary cables for this system are shown below.

SCSI Cable (WJ-CA10SR3) Connects with the HDD-BOX.

Coaxial Cable (with BNC Connector) Connects with the VCR or Monitor.

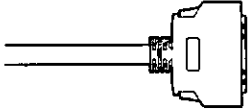
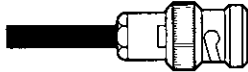
2-conductor shielded cable (with XLR-3-12C Connector) Connects with the powered speaker), cassette tape recorder, CD player, VCR.

S-VHS cable connects with the S-VHS VCR.

Cable	Use
<p>SCSI Cable (WJ-CA10SR3)</p> 	<p>HDD-BOX Connection</p>
<p>Coaxial Cable With BNC Connector</p> 	<p>VCR (Video)/Monitor Connection</p>
<p>2-conductor shielded Cable With XLR-3-12C Connector</p> 	<p>VCR (Audio) Connection</p>
<p>RCA Pin-plug Cable RCA W Pin-plug Cable</p> 	<p>Power speaker Connection Cassette Tape Recorder/CD Player/S-VHS VCR (Audio) Connection</p>
<p>S-VIDEO Cable</p> 	<p>S-VHS VCR Connection</p>

Coaxial Cable / BNC Connector

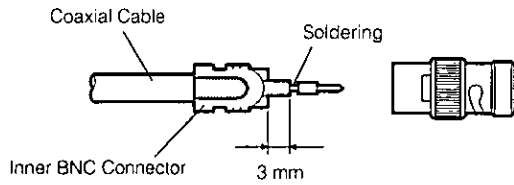

RCA Pin-plug

Connect single-conductor shielded wire as shown below.

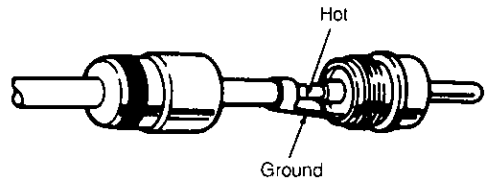

Interconnection of BNC Coaxial Cable

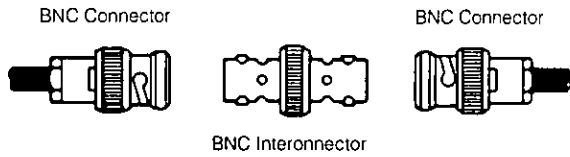

XLR-3-12C Connector

Connect the 2-conductor shielded wire as shown below.

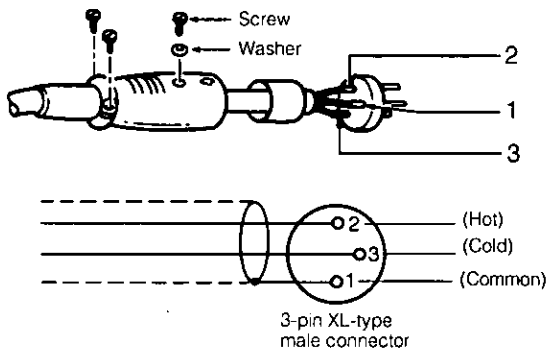

SYSTEM CONNECTION

The following system connections should be made by qualified service personnel or system installers.

HDD-BOX Connection

Refer to the Operating Instructions of the WJ-EB1000 Hard Disk Box for the Hard Disk Box Installation instructions.

Connect the SCSI VIDEO 1, 2 and 3 Connector(s) of this unit to the SCSI Input Connector(s) of the WJ-EB1000 by using the optional SCSI Cable WJ-CA10SR3.

Note: The first WJ-EB1000 should be terminated and set to ID=6.

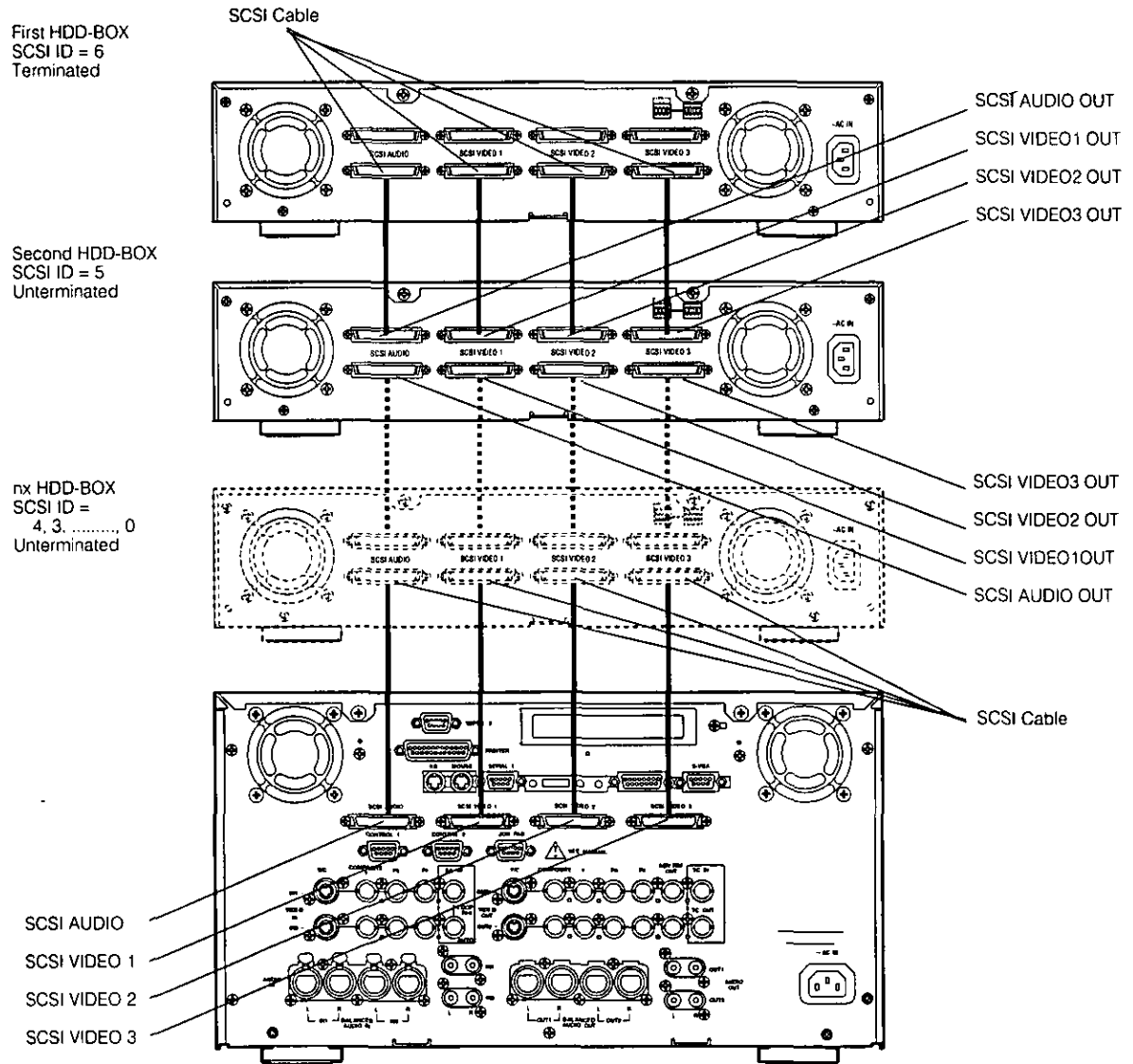

■ Key Board, Mouse and Jog Pad Connections

● Key Board and Mouse

Connect the KEY BOARD Connector of this unit to the Key Board.

Connect the MOUSE Connector of this unit to the Mouse.

Use the Key Board Extension Cable/Mouse Extension Cable (accessory) for extension if necessary.

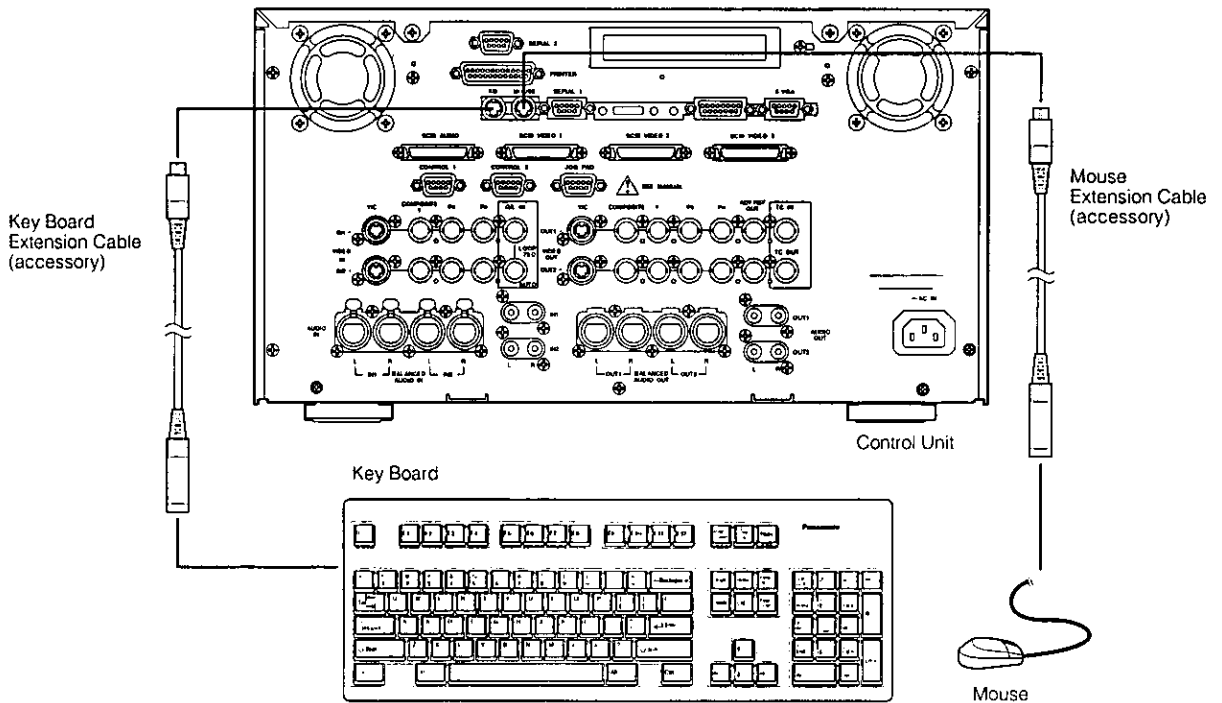

● Jog Pad Connection

Connect the JOGPAD Connector (32) of this unit to the Jog Pad.
After connecting, tighten the screws on the Jog Pad Cable (provided).

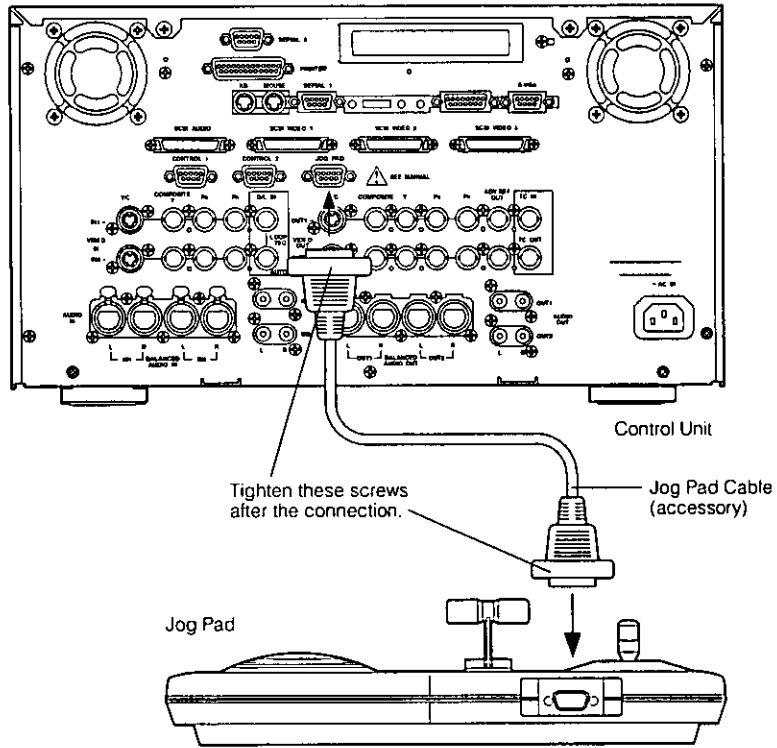

■ Monitor Connection

● Computer Display Connection

Connect the S-VGA Connector of this unit with the computer display.
The usable computer display is shown in the following.

Resolution 1024 x 768 dot
Horizontal Scanning Frequency 35 kHz
Vertical Scanning Frequency 86 Hz

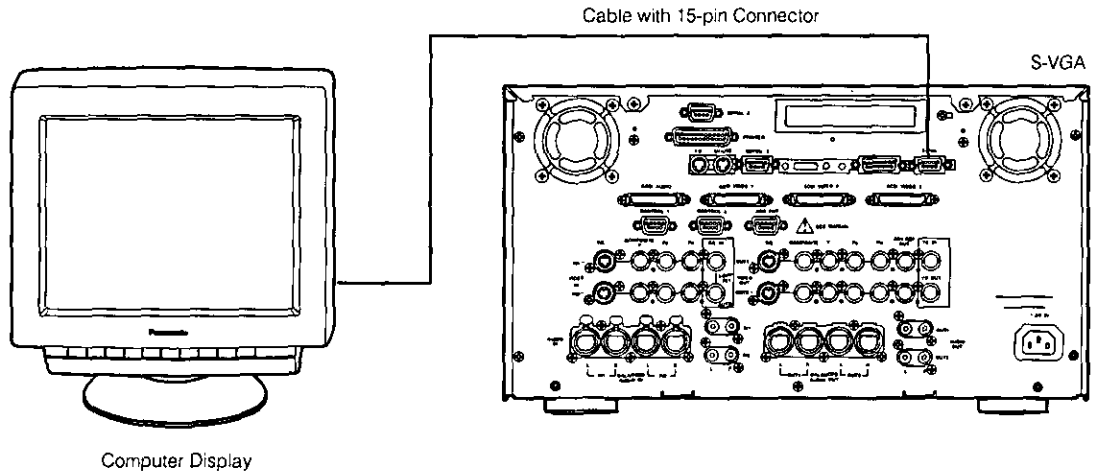

● VIDEO Monitor Connection

Connect the COMPOSITE Connector of this unit with the video monitor.

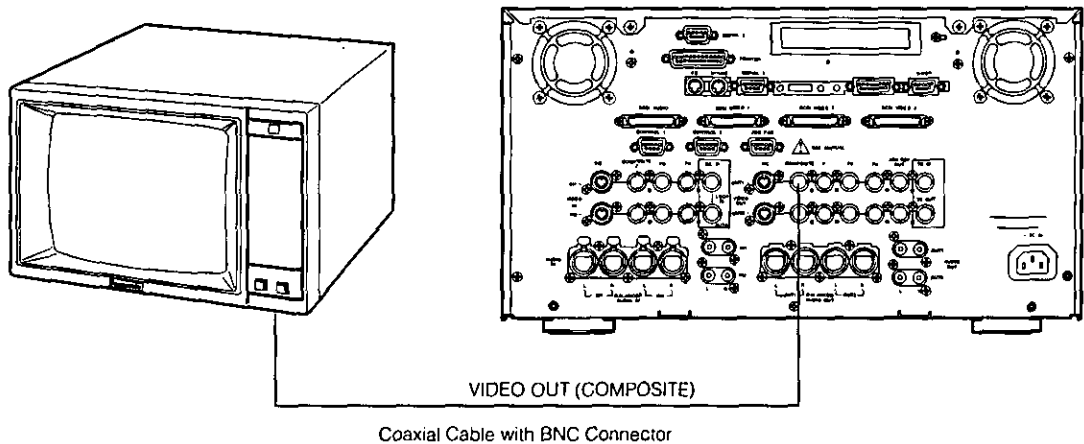

■ VCR Connection

● M II Format VCR

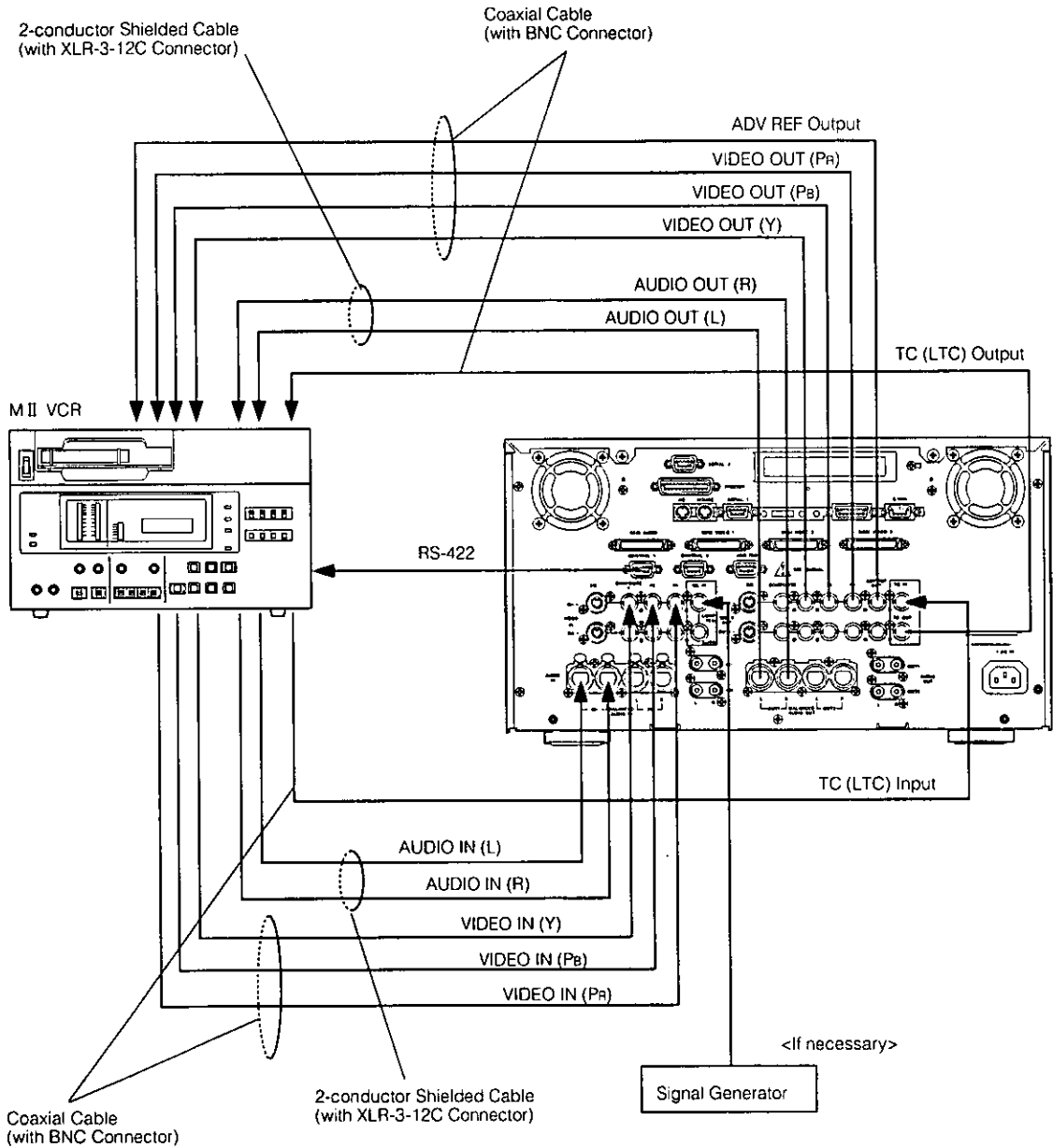

● S-VHS VCR

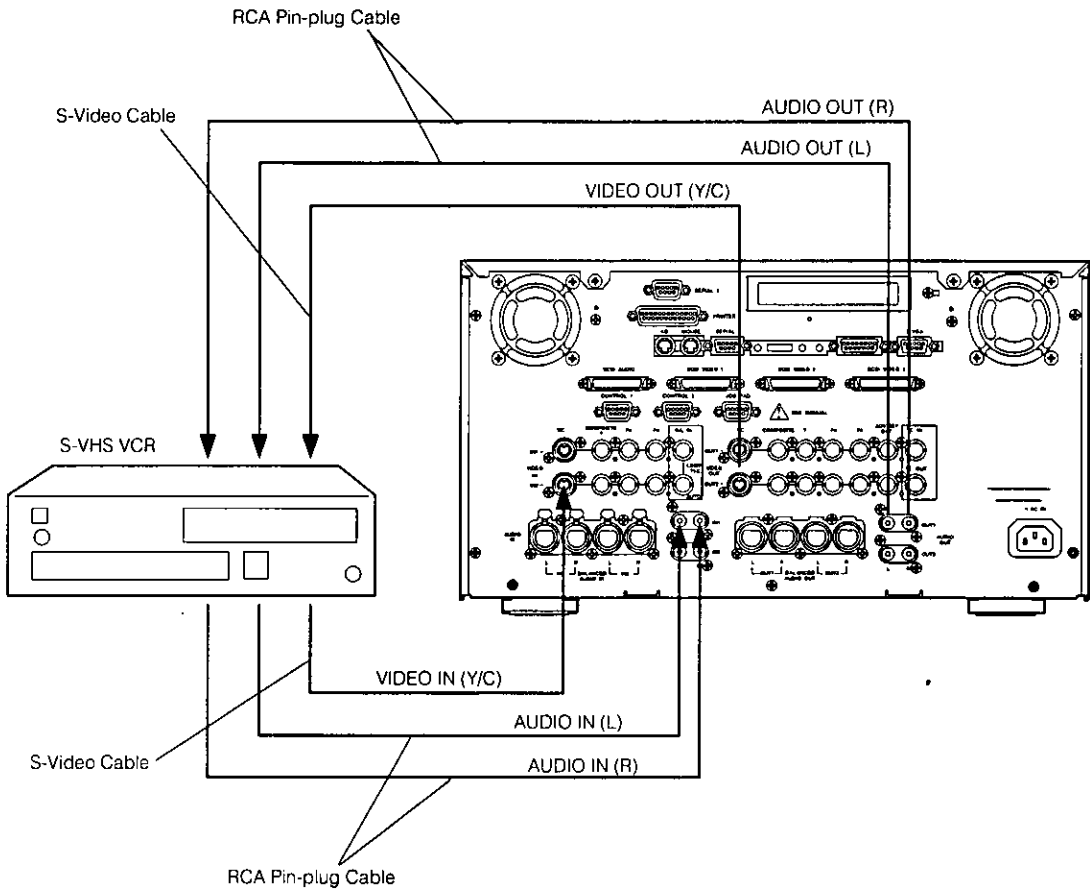

■ Powered Speaker, Cassette Tape Recorder or CD Player Connection

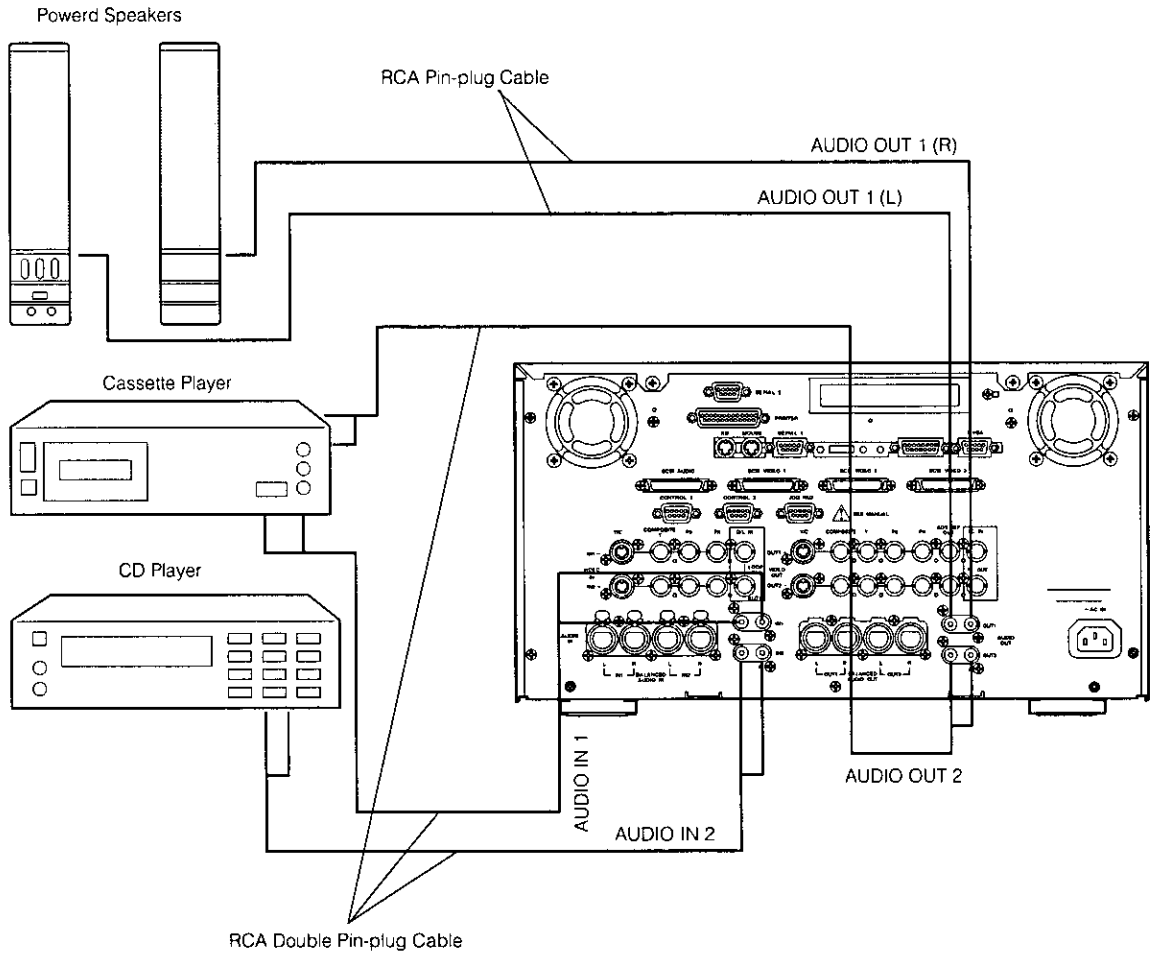

POWERING MAIN UNIT ON AND OFF

Power On

1. Turn on the power of the HDD-BOX and all peripheral equipment in the system.
The power indicator of the HDD-BOX lights red.
2. Turn on the power of this unit.
The Power Indicator (2) of this unit lights and the system is activated.

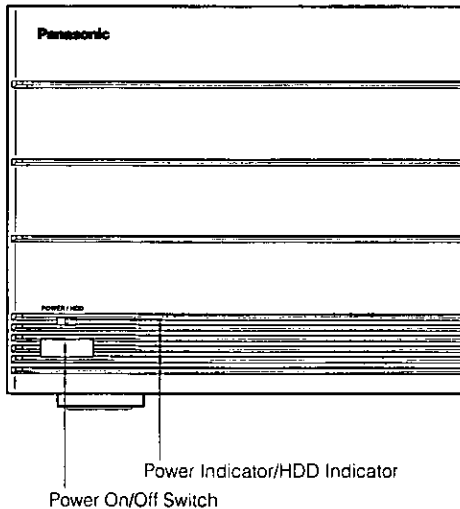

Power Off

CAUTION:

Be sure to turn off the power of this unit only after the nonlinear AV workstation software is closed.

Otherwise, the data on the HD or HDD unit may be corrupted.

1. Quit the software and Windows.
MS-DOS Prompt Screen is displayed.
Refer to the Users Manual of the WJ-MX1000A for details.
2. Turn off the power of the peripheral equipment.
3. Turn off the power of this unit.

OPERATING PROCEDURES

Refer to the User's Manual or Reference Manual for more details.

Starting the System

1. Turn on the power of the peripheral equipment in the system.
2. Then turn on the Main Unit.

The system starts and the initial window (Tool Box, Bin Manager or Bin Window) appears on the Computer Display.

Computer Display is shown below.

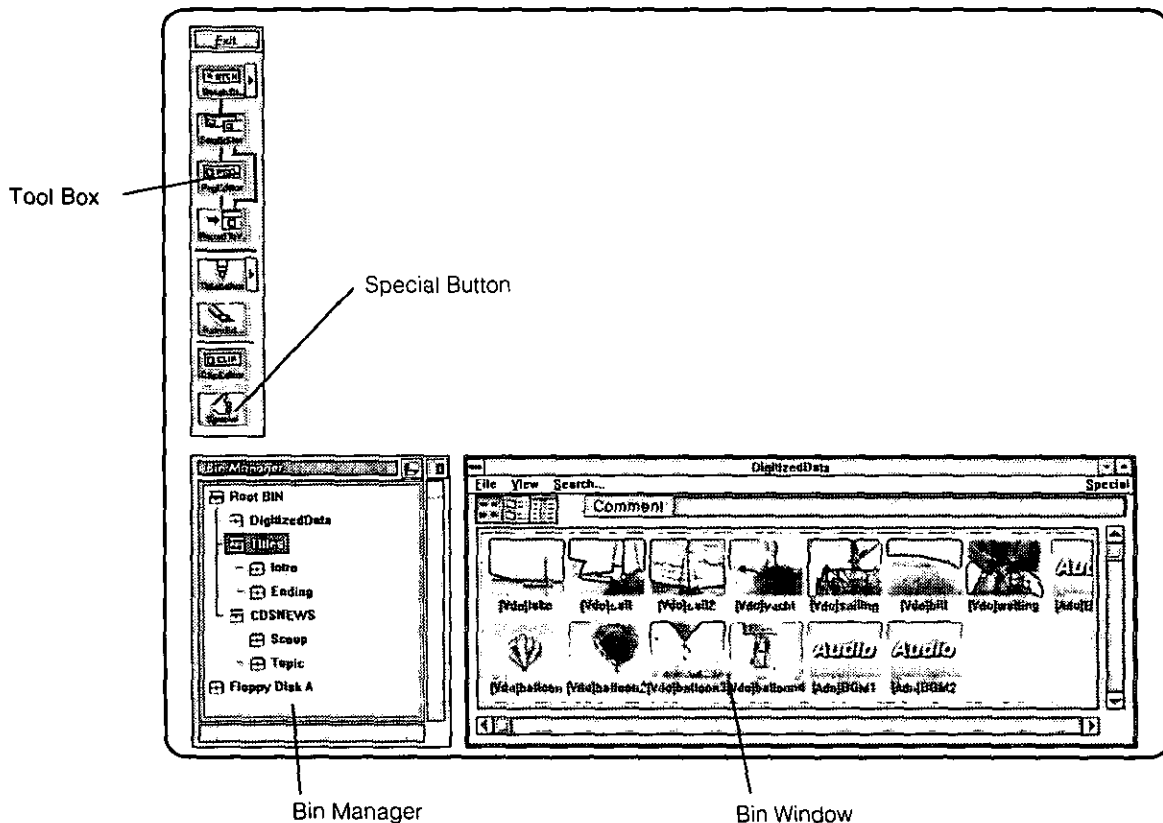

Closing the System

1. Click "Exit" on the Tool Box.
2. Click "OK".
3. Turn off the power of the peripheral equipment in the system and then the Main Unit.

■ Installing the Software Package

You should install the application program (provided on floppy disks with the WJ-AS1000B) into the Main Unit to operate this system.

Refer to "Windows Quick User's Guide" for the basic operation of Windows.

Note : Back-up MS-DOS and Windows before the installations of the application program and fonts.

Installing the Application Program

1. Turn on the peripheral equipment in the system.
2. Then turn on the Main Unit.
Windows executes.
3. Select the program manager and press the Alt + F keys.
The Pull Down menu is displayed.
4. Click "RUN....".
5. Insert the [DISK No1] floppy disk into the FDD.
6. Type "A:\SETUP" from the key board and click "OK".
The initial setup window appears.
7. Click "Continue".
The input screen appears.
8. Click "Continue".
And then type your name, company and the serial number of the main unit from key board.
9. Click "Continue".
The Locale Dialog Panel is displayed.
10. Select "NTSC [English]" and click "Continue".
The Confirmation Dialog Panel is displayed, then click "Install".
11. "Please insert the diskette labeled:disk2" is displayed.

12. Insert "Disk No2" floppy disk into the FDD and click "OK".
13. Copy the contents of all floppy disks into the Main Unit according to the message on the computer display.

■ Installing Fonts

1. Turn on the Main Unit.
The application program activates.
2. Double click "Special" on Tool Box.
The Setup panel appears.
3. Click "Font" on the Setup Panel.
Click "Append All" and combine the necessary fonts with the application program.

■ Device Setting

Refer to the Reference Manual of WJ-AS1000B for more details.

1. Double click "Special" in the Tool Box.
2. Double click "Device" in the Setup Panel.
"VCR SETUP" window is displayed.

Device Setup Window

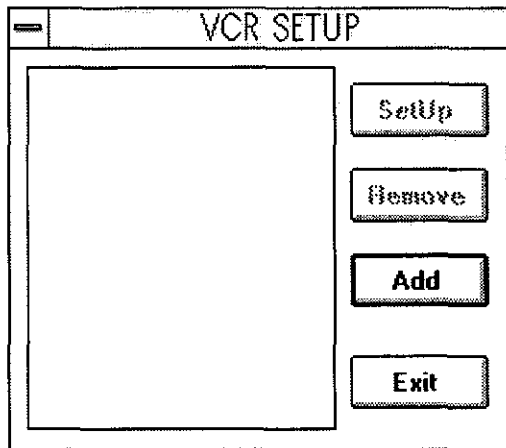

3. Click "SetUp" in the Device Window.
"CONNECTION SETUP" panel is displayed.

Connection Setup Panel

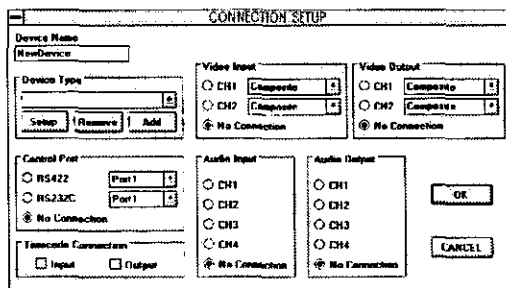

4. Set the necessary items.
5. Click "SetUp" or "Add".
"ATTRIBUTE SETUP" panel is displayed.

Attribute Setup Panel

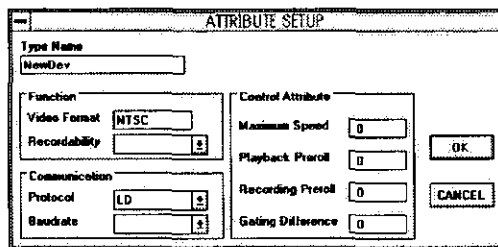

6. Set Function, Communication and Control Attributes.

■ Operation Confirmation

Refer to the Reference Manual for the HD Maintenance tools.

1. Double click "Special" in the Tool Box.
"Setup Panel" is displayed.
2. Double click "AV HDD" to display "HD Maintenance tool" panel.

HD Maintenance Setup Panel

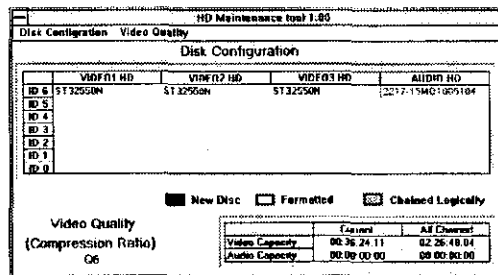

3. The HDD's model number installed in each Hard disk box is displayed.

Note: All of the installed HDDs should be displayed with the color blue.

No Display

- Confirm the SCSI cable connections between the HDD-Box and the main unit.
- If no problem is found with the connection, refer to qualified service personnel.

Black Display

- The installed HDD (in the HDD-Box) can not be initialized.
In this case , refer to qualified service personnel.

Red Display

- Open the Pull Down menu for Disk Configuration. Click on "Chain Disks" to logically format.

Caution

- It is important to make a Back-up copy of HDDs, MS-DOS and Windows. Backing up your files and disks ensures that you won't lose information if the original is lost or damaged.
- For backing up, 16 floppy disks (6 for MS-DOS and 10 for Windows) are required.

■ Back-up of MS-DOS

1. Provide 6 pcs. of formatted floppy disks.
2. Turn on the Computer Monitor and Main Unit.
3. Close Windows.
MS-DOS Prompt (C : \DOS>) is displayed.
4. Type "C : \B K U P D O S" and press ENTER.
5. Insert the floppy disk into the Floppy Disk Drive according to the message.
6. Write DOS-1,2...6 on the labels of the backed-up floppy disks.

■ Back-up of Windows

1. Provide 10 pcs. of formatted floppy disks.
2. Type "C : \B K U P W I N" and press ENTER.
3. Insert the floppy disk into the Floppy Disk Drive according to the message.
4. Write WIN-1,2...10 on the labels of the backed-up floppy disks.

■ Re-storing MS-DOS

Caution:

The following procedure will erase all data in your HDD.
If you need to replace MS-DOS only, type "N" at step 4, and 7.

1. Provide the 6 pcs. of backed-up MS-DOS floppy disks.
2. Insert the [DOS-1] floppy disk into FDD.
3. Turn on peripheral equipment, then turn on the Main Unit.
[Continue?] is displayed. Type "Y".
4. [FDISK?] is displayed.
Type "Y".
Set the partition of DOS.
5. Input 1 ENTER 1 ENTER Y ENTER and press ESC.
[FDISK?] is displayed.
6. Type "N".
[FORMAT C : ?] is displayed.
7. Type "Y".
The HDD in the Main Unit is initialized.
[Overwrite dos?] is displayed after completing the initialization.
8. Type "Y". Restore the floppy disk from [DOS-2] to [DOS-6], according to the message.
[COPY AUTOEXEC.BAT,CONFIG.SYS Y/N] is displayed after completing the restore.
9. Type "Y". Insert the [DOS-1] floppy disk into FDD again.
10. [COMPLETED] is displayed. Pull out the floppy disk.
11. Turn off and then on the Main Unit.
MS-DOS executes.
12. Next re-store Windows.

■ Re-storing Windows

1. Provide the 10 pcs. of backed up Windows floppy disks.
2. Confirm the display of "C : \>".
3. Insert the [WIN-1] floppy disk into the FDD, then type "A : ." and press ENTER.
"C : \>" changes to "A : \>".
4. Type "S E T U P" and press ENTER to re-store the floppy disks from [WIN-1] to [WIN-7].
5. [WIN-7] is not used in some setting modes.

■ Setting of monitor (S-VGA) for personal computer

1. Insert the [WIN-8] floppy disk into the FDD, then type "A:\Install A: C:" and press ENTER.
2. The Driver Installation screen appears. Select "Install Windows 3.1 Driver & Galileo Utility", then press ENTER.
3. The screen to input the path appears. Confirm that the path is "C:\WINDOWS", then press ENTER.
4. "Hit any key to continue." is displayed. Press any key.
5. Select "Exit", then press ENTER.
"Do you really want to exit this program?" is displayed. Press ENTER.
6. Type "Win" and press Enter to start Windows.
7. Double-click "Galileo" in the control panel to open it.
8. Click "Resolution" and select 1024 x 768, then select 256 Colors from Color Depth. Furthermore, click "Switches", and confirm that the top item is Small Font Enabled.
9. Click "OK", then click "Yes, Use Current Drivers", and "Restart Windows" in order. If Windows starts normally, the monitor has been set.

■ Swap File Setting

1. Type W I N and press ENTER to execute Windows.
2. Double Click Control Panel in the Main Group to display 386 Enhanced icon.
3. Double click 386 Enhanced icon.
386 Enhanced panel is displayed.
4. Click VIRTUAL MEMORY.
The VIRTUAL MEMORY panel is displayed.
5. Click CHANGE.
6. Input 39000 into New Size and click "OK".

ADJUSTMENT

● Gen-lock Adjustment

Phase adjustments must be performed by using the switches inside the Front Panel when external synchronizing signals are supplied to the system .

As an example , the gen-lock adjustment is shown below using a two-channel oscilloscope (or wave form monitor), vector scope and signal generator.

1. Connect the oscilloscope, vector scope and signal generator with the Main unit WJ-MX1000A.
The reference signal is supplied from the signal generator .
The video signal should be a composite signal.
2. Turn on the external reference switch of the vector scope.
3. Remove the Front Panel by pressing down the Front Panel Remove Buttons (7) on the left and right sides.

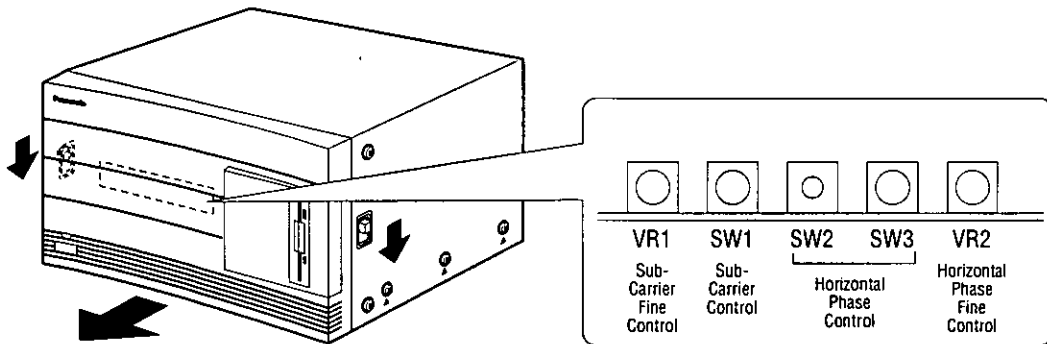
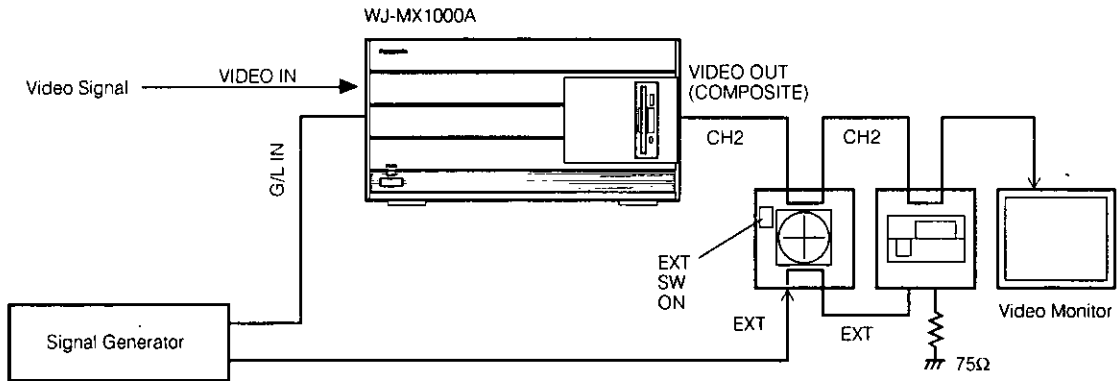

● Color Phase Control

The sub-carrier can be adjusted by using the SW1 and VR1.

1. Turn the SW1 to clockwise ; 0° , 90° , 180° , 270°
Turn the SW1 to counterclockwise ;
 270° , 180° , 90° , 0°
2. Perform the fine adjustment with the VR1.

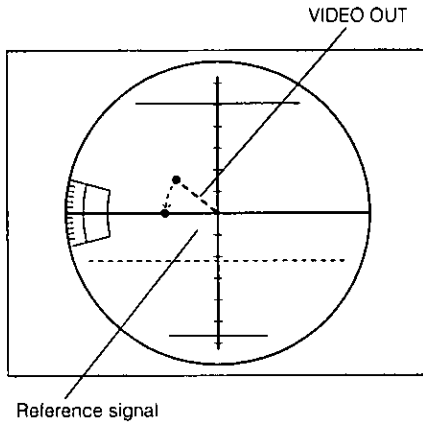

● Horizontal Phase Control

Observe the waveform of the external synchronizing input signal (black burst signal) and video output signal on a two-channel oscilloscope.

Then match the horizontal phase of both signals by using the SW2, SW3 and VR2.

1. The horizontal phase course 1 adjustment can be performed with the SW3 (1 μ s).
2. The horizontal phase course 2 adjustment can be performed with the SW2. (70 ns).
3. The horizontal phase fine adjustment can be performed with the VR2.

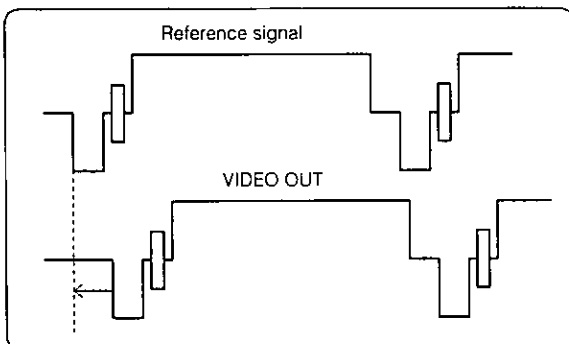

● Install the Front Panel

After the above adjustments, install the front panel as shown below.

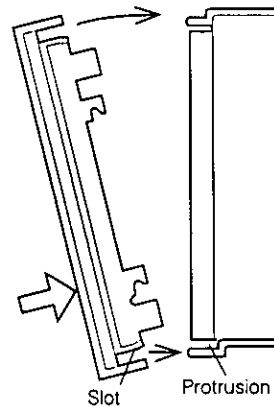
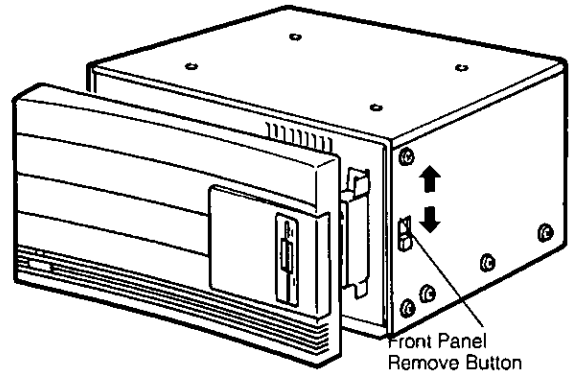

1. Press down (↓) the Front Panel Remove Buttons (7) on both the left and right sides.
2. Place the panel as shown in the above figure. Insert the slot on the panel to the protrusion, then press the panel to the front of the Main Unit.
3. Press up (↑) the Front Panel Remove Buttons (7) on both the left and right sides.
4. Confirm the Front Panel is tightened firmly.

SPECIFICATIONS

Video

Video Input

Input Connectors	2 sources (selectable from Composite, Y/C, Y/P _B /P _R)
Composite:	1.0 Vp-p/75 ohms (BNC)
Y/C:	Y: 1.0Vp-p/75 ohms
	C: 0.286 Vp-p/75 ohms (Y/C terminal)
Component:	Y: 1.0Vp-p/75 ohms (BNC)
	P _B /P _R : 0.486Vp-p or 0.7Vp-p, 75 ohms (BNC) (Setup 7.5 IRE)

Video Output

Output Connector	2 outputs (simultaneously from Composite, Y/C, Y/P _B /P _R)
Composite:	1.0Vp-p/75 ohms
Y/C:	Y: 1.0Vp-p/75 ohms
	C: 0.286Vp-p/75 ohms (Y/C terminal)
Component:	Y: 1.0Vp-p/75 ohms (BNC)
	P _B /P _R : 0.486Vp-p or 0.7Vp-p, 75 ohms (BNC) (Setup 7.5 IRE)

Synchronization

Gen-Lock Input	1.0Vp-p/75 ohms (BNC), with loop-through output (x1)
ADV.REF output	Sync: 0.286Vp-p, 75 ohms
	Burst: 0.286Vp-p, 75 ohms

Audio Input

Selectable from 4 sources	
Source 1/2	+4dBm, 600 ohms balanced (3-pin XLR connector)
Source 1/2	-6dBs, 20 kohms, unbalanced (RCA pin jack)

Audio Output

4 outputs (simultaneous)	
Ch. 1/2	+4dBm, 47 ohms balanced (3-pin XLR connector)
Ch. 1/2	-6dBs, 75 ohms, unbalanced (RCA pin jack)

Other Inputs/Outputs

LTC time code Input	x1 (BNC)
LTC time code output	x1 (BNC)
SCSI connector	x4 (Audio, Video 1, Video 2, Video 3, SCSI-2 standard, 50-pin half pitch connector, bellows type)
VTR control connector :	RS422, 9 pin x2 (D-sub)
Jog Pad connector:	9 pin x1 (D-sub)

PC

CPU :	Pentium Processor, 100MHz
OS :	MS-DOS Ver. 6.22, Windows Ver. 3.1
Main Memory :	16MB
Built-in Hard Disk Drive :	850MB (IDE) x1
Floppy Disk Drive :	1.44MB x1
Card Slot :	ISA x1 (supplied by Panasonic only)
SVGA connector :	15 pinx1 (D-Shell, female), 1024x768 dots, 256 colors, Scanning: 35kHz (horizontal), 86 Hz (vertical)
Parallel connector:	25 pin x1 (D-Shell, female)
Serial connector :	9 pin x2 (D-Shell, male)
Mouse :	6 pin x1 (Mini-Din, female)
Keyboard :	6 pin x1 (Mini-Din, female)

Video Performance

S/N Ratio *:	55dB (Y/P _B /P _R), 53dB (Y/C), 50dB (Composite)
DG, DP *:	5%, 3°
Frequency Response *:	4.5MHz, +0dB, -3dB (Y/C, Y/P _B /P _R)
Sampling Frequency:	13.5MHz, 4:1:1, 8 bit component
Y/C Separation:	3 lines, digital logical comb filter
SC-H:	±30°
Compression:	MOTION JPEG
Compression Quality:	Q6, Q8, Q11, Q23
Recording Time:	Approx. 6 min/GB (Q6) Approx. 8 min/GB (Q8) Approx. 11 min/GB (Q11) Approx. 23 min/GB (Q23)

Title Graphics

Resolution:	640 x 480 dots Y, U, V, α, 8 bit component each
Font :	True type

Audio Performance

S/N Ratio	More than 70dB (1kHz, XLR OUT)
Dynamic Range	More than 88dB
Total Harmonic Distortion	0.05% (1kHz)
Frequency Response	20kHz, +0, -3dB, 20Hz, +0, -3dB
Sampling Frequency	48kHz, 16 bit
Mixing	Stereo 4 channels
Effector	EQ, Reverberation
Recording Time	Approx. 86min/GB

Others

EDL Output	CMX 3600 format
Graphic Conversion	TIFF file

General

Power Supply	120V AC, 60Hz
Power Consumption	110W (with optional Video Board)
Ambient Operating Temperature	32°F-95°F (0°C - 35°C)
Ambient Operating Humidity	10% - 90%
Weight	Main unit: 49.5 lbs (22.5 kg) Jog pad: 2.6 lbs (1.2 kg)
Dimensions	See dimensional drawings

Weight and dimensions indicated above are approximate.
Specifications are subject to change without notice.
This product might be subject, to export control regulations.

* : Without Compression

Panasonic

Broadcast & Television Systems Company

Division of Matsushita Electric Corporation of America

Executive Office One Panasonic Way 3F-5 Secaucus NJ 07094

Regional Offices

EASTERN ZONE 43 Hartz Way Secaucus NJ 07094 (201) 348 7620

CENTRAL ZONE 1707 North Randall Road Elgin, IL 60123 (708) 468 5200

SOUTHERN ZONE

Dallas Region 4500 Amon Carter Blvd Fort Worth TX 76155 (817) 685 1117

Atlanta Region 1225 Northbrook Parkway Suite 1-160 Suwanee GA 30174

Panazip 11 (404) 338 6841 fax (404) 338 6741

Law Enforcement Video Products 1225 Northbrook Parkway Suite 1 160 Suwanee GA

30174 Panazip 11 (404) 338 6844 fax (404) 338 6721

WESTERN ZONE

Seattle Region 1200 Westlake Ave North Suite 508 Seattle WA 98109 (206) 285-8883

Los Angeles Region 6550 Katella Ave 17A 1 Cypress CA 90630 (714) 373 7271

Government Marketing Department 52 West Gude Drive Rockville MD 20850 (301) 738-3840

PANASONIC CANADA INC

5770 Ambler Drive Mississauga Ontario L4W 2T3 Canada (905) 624 5010

PANASONIC SALES COMPANY

DIVISION OF MATSUSHITA ELECTRIC OF PUERTO RICO, INC

San Gabriel Industrial Park 65th Infantry Ave KM 9 5 Carolina Puerto Rico 00630 (809) 750-4300